

E type

APPLICATION PRINTING PRESS / CHEMICAL LIQUID SUPPLYING EQUIPMENT etc.



Characteristics / Specification DC24V

FLOW COVER RANGE	200 ~ 1000ml/min		
FLOW PER ROTATION	2.1 ~ 3.8ml/r		
APPLICABLE TUBE	P-PHARMED TUBE N-NORPRENE TUBE S-SILICONE TUBE		
CONNECTING TUBE	INSIDE DIAMETER: $\phi 6$ mm		
CLAMP TYPE APPLICABLE TUBE	INSIDE DIA. $\phi 6$ mm \times OUTSIDE DIA. $\phi 8$ mm POLYETHYLENE TUBE NYLON TUBE		
DISCHARGE PRESSURE	0.1MPa		

MODEL	FLOW (ml/min)		
PT-EP (24V)	350	500	1000
WEIGHT (g)	450	450	530

Setting metal working plan

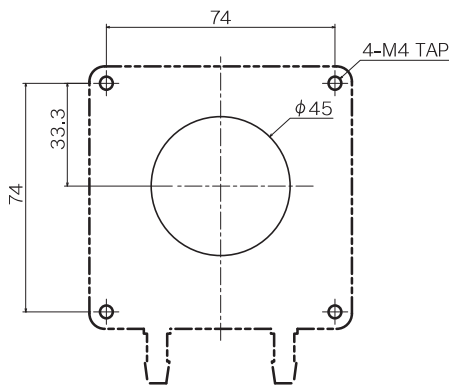

Outline drawing

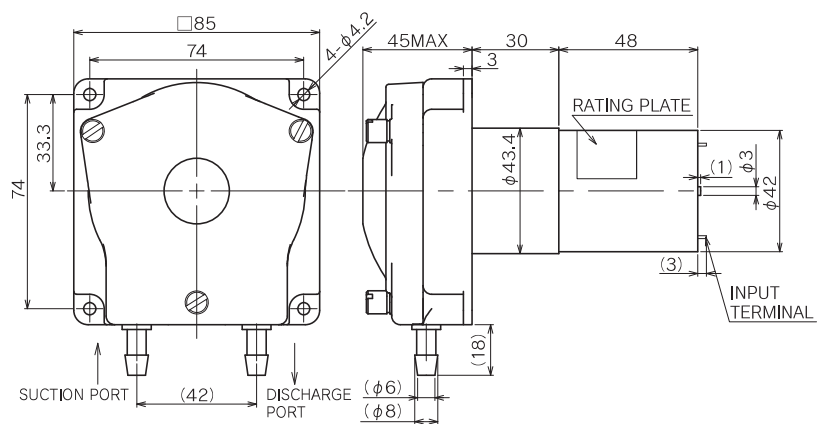

F type

APPLICATION FILLING MACHINE / LAUNDRY / INK JET etc.



Characteristics / Specification DC24V

FLOW COVER RANGE	550 ~ 1400ml/min		
FLOW PER ROTATION	7.5ml/r		
APPLICABLE TUBE	P-PHARMED TUBE S-SILICONE TUBE		
CONNECTING TUBE	INSIDE DIAMETER: $\phi 8$ mm		
DISCHARGE PRESSURE	0.1MPa		

MODEL	FLOW (ml/min)		
PT-FP (24V)	550	1000	1400
WEIGHT (g)	780	780	780

Setting metal working plan

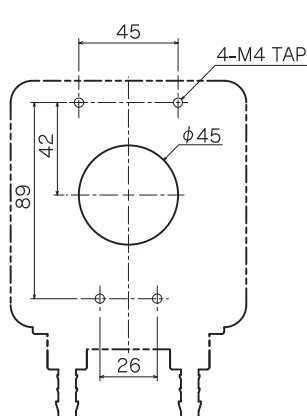

Outline drawing

