

D type

APPLICATION CLEANING EQUIPMENT / CHEMICAL LIQUID SUPPLYING EQUIPMENT etc.



Characteristics / Specification DC24V

FLOW COVER RANGE	50 ~ 200ml/min		
FLOW PER ROTATION	0.6ml/r		
APPLICABLE TUBE	P-PHARMED TUBE N-NORPRENE TUBE S-SILICONE TUBE		
CONNECTING TUBE	INSIDE DIAMETER: ϕ 4mm		
CLAMP TYPE APPLICABLE TUBE	INSIDE DIA. ϕ 4mm×OUTSIDE DIA. ϕ 6mm POLYETHYLENE TUBE NYLON TUBE		
DISCHARGE PRESSURE	0.1MPa		

MODEL	FLOW (ml/min)		
PT-DP1 (24V)	50	100	200
WEIGHT (g)	236	345	345

Setting metal working plan

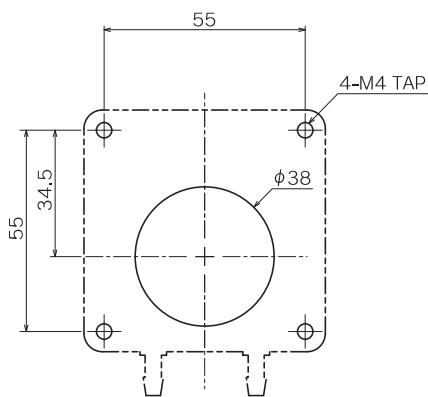

Outline drawing

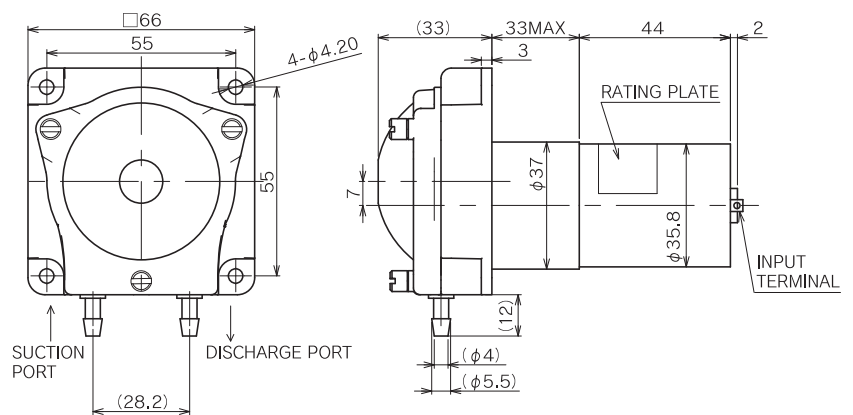

B type

APPLICATION PRINTING PRESS / CHEMICAL LIQUID SUPPLYING EQUIPMENT etc.



Characteristics / Specification DC24V

FLOW COVER RANGE	50 ~ 450ml/min		
FLOW PER ROTATION	1.55ml/r		
APPLICABLE TUBE	P-PHARMED TUBE N-NORPRENE TUBE S-SILICONE TUBE		
CONNECTING TUBE	INSIDE DIAMETER: ϕ 5mm		
DISCHARGE PRESSURE	0.03MPa		

MODEL	FLOW (ml/min)		
PT-BP1 (24V)	50	150	450
WEIGHT (g)	500	500	500

Setting metal working plan

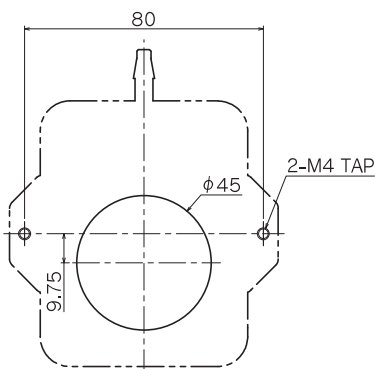

Outline drawing

